



AQUAFOG®

TurboXE-660

The **XE-660 (1/3HP, 50Hz)** is perfectly suited for small to mid-size applications requiring 1-2 fogging fans. This model is a little quieter than the larger XE-1500, but still produces a good quality fog and is very energy efficient.

TurboXE-660 Description

Designed to condition the air, not to wet or mist surfaces or specific objects, the high capacity TurboXE foggers produce a true fog for humidification, evaporative cooling, and chemical application in many different industries. TurboXE works best in almost fully contained areas for humidification, completely contained areas for chemical application and partially contained, ventilated areas for evaporative cooling.

Unlike other fog systems, TurboXE Foggers can accept ordinary water supplies, even well or pond water without the risk of clogging. The secret is in the nozzle-free, self-flushing atomization system that forces liquids through passageways in the fan blades, atomizing as the liquid exits the blades. In addition, TurboXEs do not require high-pressure lines. Ordinary pressurized water lines are more than enough, and units can even be gravity-fed. By eliminating specialized pumps and filtering equipment, AquaFog saves time and reduces costs. The unique atomization process combined with the fan's forced circulation provides high quality fog and uniform fog distribution.

The powerful TurboXE is engineered to withstand humid conditions as high as 100% RH and above, and corrosive environments containing salts, lime, ammonia and other acidic compounds. Units are constructed of impenetrable components like Nema 4 connections, all 304 SST hardware, UV stabilized polyethylene plastics, PVC dip-coated steel, and sulfuric anodized aluminum. XE fans are also standard-equipped with a Baldor wash-down-duty motor that is specifically designed for wet, corrosive environments.

TurboXE Fan Features

- Standard-equipped with a Baldor wash-down-duty motor for strength and reliability in wet, harsh environments.
- Uses ordinary water and power supply to produce high quality, high volume fog.
- Fans can be stationary or equipped with oscillation.
- Excellent for safe, effective chemical fogging. Used for liquid pesticide and fungicide application, insecticide use and foliar feedings.
- Capable of continuous duty operation.

XE-660 Fans are standard equipped with a dark green housing and a dual voltage, white epoxy painted wash-down-duty™ (WDD) motor 120/240V, 1ph, 50Hz.

Also Included With Every Fan Unit

- Adjustable-angle hanging bracket
- Choice of visual flowmeter panel with strainer
- 12' SJO indoor/outdoor, heavy-duty power cord
- 20' Poly-Flo water line tubing
- 10' water drainage line
- 100% stainless steel hardware
- Easy-to-follow operator's manual

TurboXE-660 Specifications

Dimensions

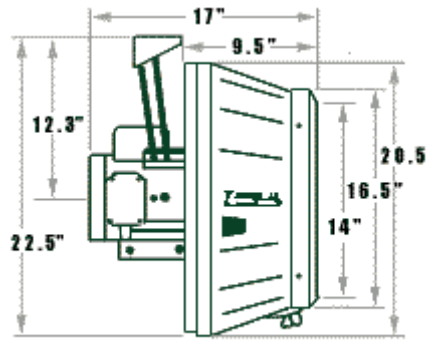

Aquafoq Fan Dimensions

Aquafoq units produce small particles averaging 25 microns in size and feature flow control for adjustment of the amount of liquid being fed to the fogging fan. At rates near full capacity, 95% of the particles produced are small enough to stay airborne.

Propulsion Distance	25'
Dispersion Distance	50'
Weight w/ Wash Down Motor	42 lbs.
Max. Dry Fog Output	14 GPH - 1/3 HP Turbo XE
Energy Consumption	6 AMPS @ 120 V - 1/3 HP
CFM Rating	2,580 - 1/3 HP Turbo XE
Noise @ 10 ft. Distance	69 - 73 dB(A) - 1/3 HP

MechPro

P O Box 2448, Krugersdorp, 1740, 47 De Wet Street, Krugersdorp-North
Tel/fax (+2711)660 3500, Cell. (+2782) 336 1284
<http://www.mechpro.co.za> e-mail – sales@mechpro.co.za